

**AN INSIDE LOOK
AT THE
TECHNOLOGIES
BEHIND THE
BEST-ASSEMBLED
VEHICLES.**

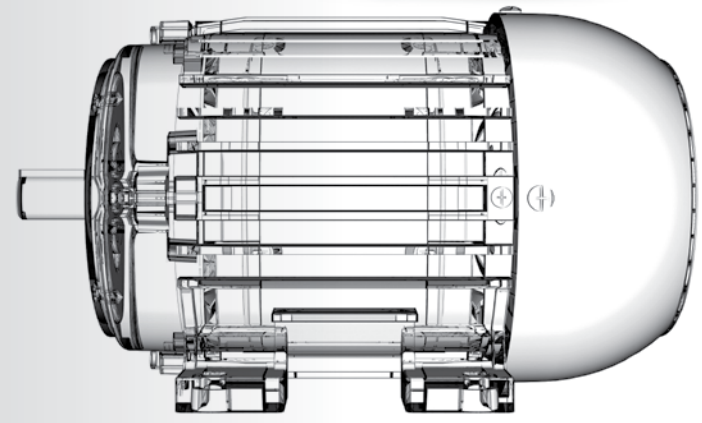
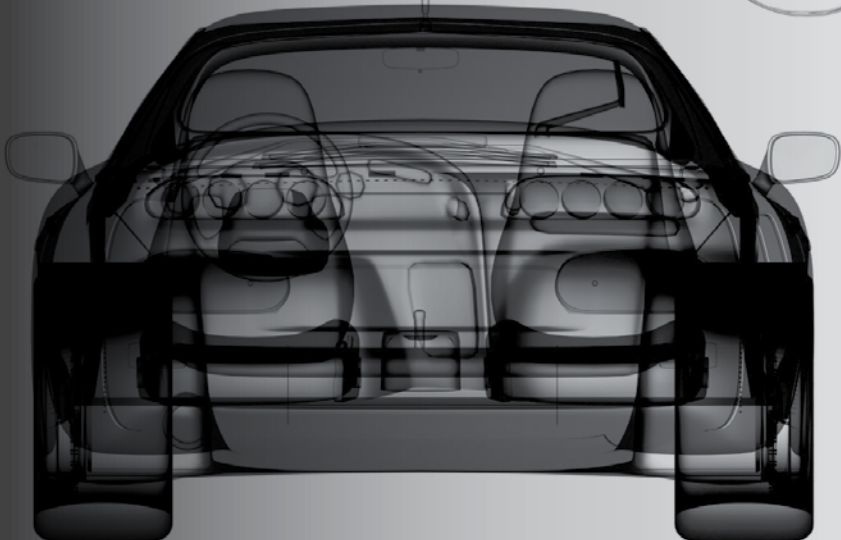
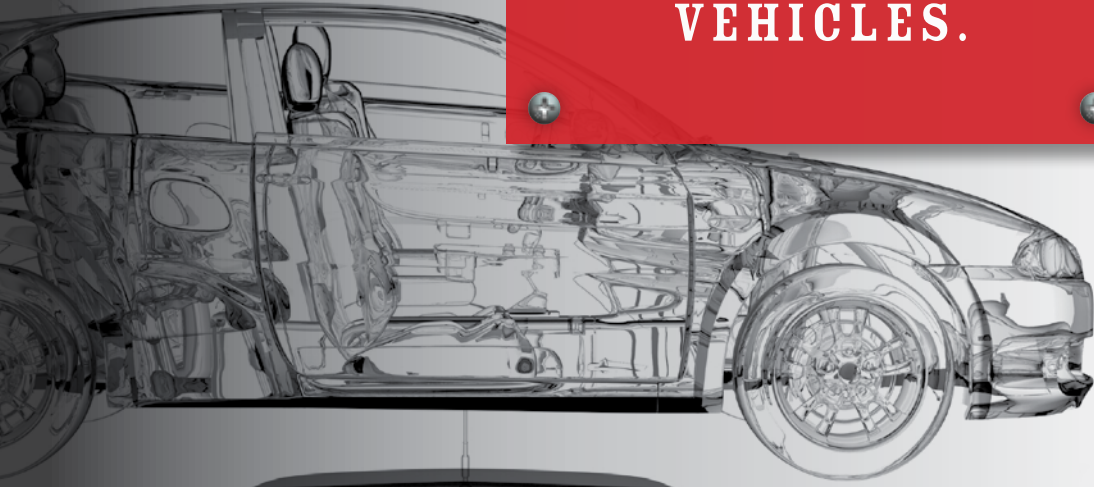

MORTORQ® SUPER SPIRAL DRIVE SYSTEM

Low-profile head with super high-strength recess offers elegance and functionality.

The MORTORQ® SUPER high-strength spiral drive system is the most advanced industrial drive system available today for use in automotive/transportation manufacturing. Featuring an exceptionally shallow recess, it sets the standard for strength and functionality. Its recess geometry provides full driver contact over the entire mating surface of the recess wings. This results in extreme high-torquing capability without risk of damage to the fastener or surrounding head area. Minimal head height reduces the weight of fastened components. Made with less material and light in weight, MORTORQ SUPER contributes to greener automotive products.



FEATURES

- Low-profile head
- Super high-strength recess
- Elegant appearance while offering a higher level of security
- Full driver contact of recess
- Optional recess ramps facilitate rotating driver bit engagement

BENEFITS

- Offers extreme high-torque capabilities
- Promotes lighter weight assemblies
- Reduces component materials costs
- Eliminates clearance problems
- Aids in disassembly for more effective maintenance and service
- Speeds assembly while maximizing torque control
- Expands design options

APPLICATIONS

DRIVER SIZES:
MTS-000 THRU MTS-8

SCREW SIZES:
M2 (#2) THRU M20 (7/8 IN)

TRANSMISSIONS
TRANS-AXLES
DIFFERENTIALS
SUSPENSION COMPONENTS
INTERIOR COMPONENTS
DOOR PANELS & ATTACHMENTS
DOOR FRAMES & HINGES
SEATS & RESTRAINT SYSTEMS
INSTRUMENT PANELS
ACCESSORIES & ATTACHMENTS
BODY COMPONENTS & ATTACHMENTS
ENGINE & DRIVE TRAIN COMPONENTS
MACHINE SCREWS
THREAD-CUTTING SCREWS
THREAD-FORMING SCREWS

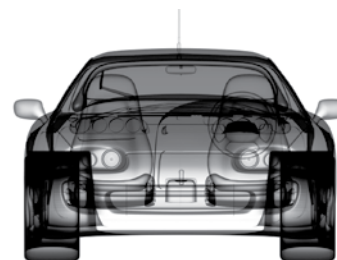
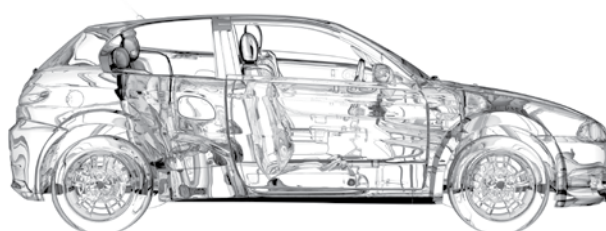
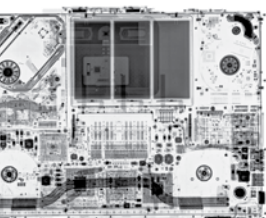

HEXSTIX® STABLE DRIVE SYSTEM

Engineered to deliver exceptional stability and alignment in one-handed applications.

The HEXSTIX® Stable Drive System increases speed and efficiency in one-handed applications of assembled components. The screw recess design has an outstanding ability to hold firmly to the driver bit at the point of assembly – with no magnetic bits or vacuum screw holders required. For maintenance and field use, standard driver bits can be used to remove or replace HEXSTIX screws.



FEATURES

- Highly compatible lobular design ensures screw sticks securely to driver bit
- Superior stability and axial alignment
- HexStix replaces traditional TORX® or generic 6-lobe screws
- Secure engagement of screw recess to driver bit maintains backwards compatibility to generic TORX drive bits
- Meets or exceeds industry strength standards for lobular drive systems

BENEFITS

- Reliable one-handed application of screws at point of assembly
- Enables operator to start the screw more easily and reduces risk of cross threading
- Magnetic bits or vacuum screw holders are not necessary
- Virtually eliminates dropped screws in assembly area and on factory floor
- Interchangeable with traditional TORX® driver bits

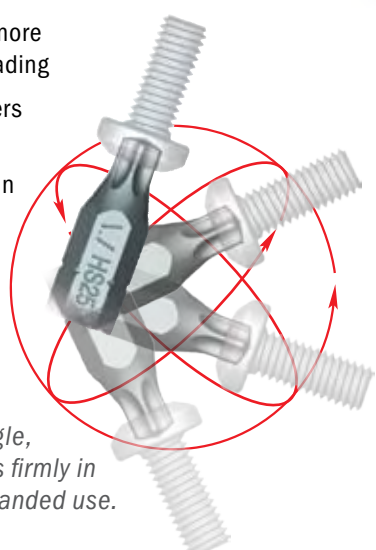

Even when held at any angle, the HEXSTIX driver bit holds firmly in the recess to enable one-handed use.

APPLICATIONS

DRIVER SIZES:
H15 THRU H50
SCREW SIZES:
M3.5 (#6) THRU M10 (7/16 IN)

TRANSMISSIONS
TRANS-AXLES
DIFFERENTIALS
SUSPENSION COMPONENTS
INTERIOR COMPONENTS
DOOR PANELS & ATTACHMENTS
DOOR FRAMES & HINGES
SEATS & RESTRAINT SYSTEMS
INSTRUMENT PANELS
ACCESSORIES & ATTACHMENTS
BODY COMPONENTS & ATTACHMENTS
ENGINE & DRIVE TRAIN COMPONENTS
MACHINE SCREWS
THREAD-CUTTING SCREWS
THREAD-FORMING SCREWS

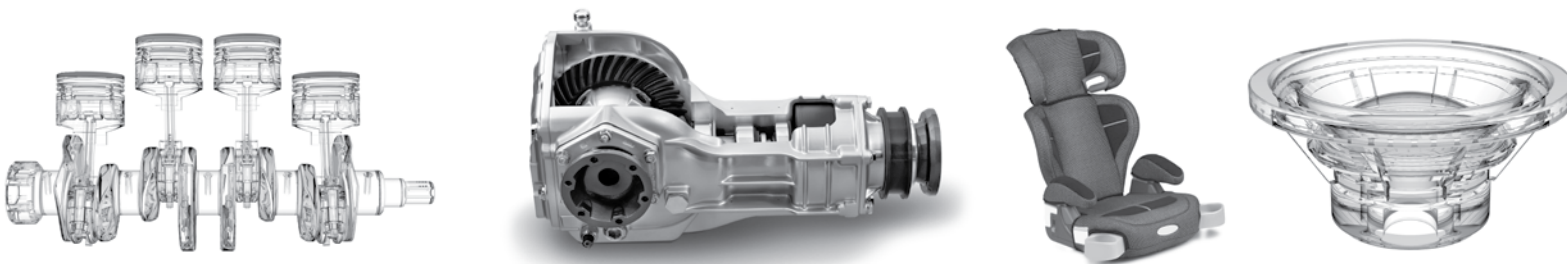

PHILLIPS SQUARE-DRIV[®] DRIVE SYSTEM

One drive system with five choices of engagement.

The benefits of the PHILLIPS SQUARE-DRIV[®] combination drive system are significant. In larger, higher torque applications where stick-fit is crucial, PHILLIPS SQUARE-DRIV is especially useful. Fasteners can be better controlled at higher torque levels for optimum clamp loads. This reduces driver bit wear and eliminates driver cam-out which can cause recess reaming, component damage/rework and operator injury.

FEATURES

- ⊕ Unique combination drive system with ACR[®] technology
- ⊕ Only three driver bit sizes required to cover the most popular size-range
- ⊕ Higher torque driving capability for thread-forming screw applications
- ⊕ Non-magnetic fastener-to-bit stick-fit
- ⊕ Distinctive head marking that easily identifies a PHILLIPS SQUARE-DRIV[®] Drive System

BENEFITS

- ⊕ Significantly enhances driving torque capability
- ⊕ Extends driver bit life
- ⊕ Facilitates one-hand fastener installation
- ⊕ Aids in disassembly for more effective maintenance and service
- ⊕ Virtually eliminates dropped screws in assembly area and on factory floor

A CHOICE OF FIVE DRIVERS

In field service operations, versatility is the mark of the PHILLIPS SQUARE-DRIV[®] combination drive system. A single drive system allows the use of five different drivers.

- ⊕ PHILLIPS SQUARE-DRIV[®]
- ⊕ PHILLIPS II[®]
- ⊕ POZIDRIV[®]
- ⊕ Square
- ⊕ Generic Phillips



APPLICATIONS

DRIVER SIZES:

0-1 THRU 3-3

SCREW SIZES:

M3 (#4) THRU M6 (1/4 IN)

SUSPENSION COMPONENTS
INTERIOR COMPONENTS
DOOR PANELS & ATTACHMENTS
DOOR FRAMES & HINGES
SEATS & RESTRAINT SYSTEMS
INSTRUMENT PANELS
ACCESSORIES & ATTACHMENTS
BODY COMPONENTS & ATTACHMENTS
MACHINE SCREWS
THREAD-CUTTING SCREWS
THREAD-FORMING SCREWS

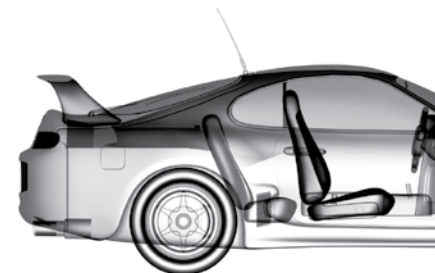

PHILLIPS II® DRIVE SYSTEM

Designed and engineered to replace generic Phillips screws.

The PHILLIPS II® Drive System has been designed to meet the ever-challenging demand of faster manufacturing assembly processes that can cause driver cam-out, resulting in component surface damage and scrapped components. It facilitates off-angle fastener driving efficiency in difficult assembly positions and reduces end-load pressure, resulting in less operator fatigue.

FEATURES

- Enhanced cruciform drive with anti-cam-out recess (ACR®) technology
- Reduced end-load pressure
- Distinctive head marking that easily identifies a PHILLIPS II® Drive System

BENEFITS

- Virtually eliminates cam-out
- Improves off-angle drive efficiency
- Reduces burred screwheads and marred components
- Lowers operator fatigue and increases productivity
- Field service compatible with generic Phillips driver bits
- Aids in disassembly for more effective maintenance and service
- Speeds assembly while reducing defects and rework



APPLICATIONS

DRIVER SIZES:

0 THRU 5

SCREW SIZES:

1.6MM (#0) THRU M12 (9/16 IN)

INTERIOR COMPONENTS
DOOR PANELS & ATTACHMENTS
SEATS & RESTRAINT SYSTEMS
INSTRUMENT PANELS
ACCESSORIES & ATTACHMENTS
BODY COMPONENTS & ATTACHMENTS
MACHINE SCREWS
THREAD-FORMING SCREWS
SCREWS FOR PANEL NUTS & INSERTS

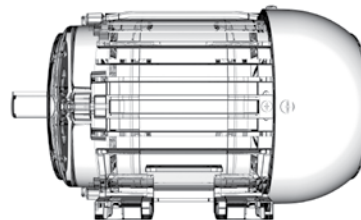
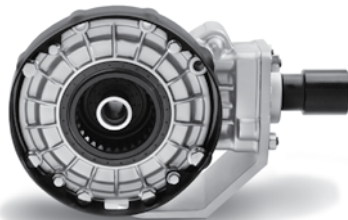
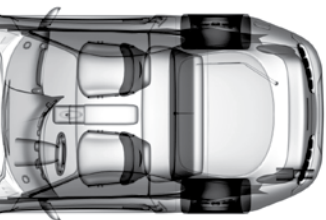
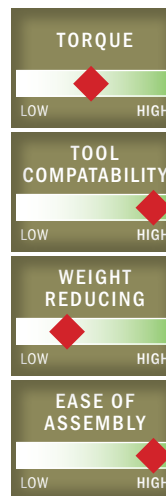

Phillips has been at the forefront of threaded fastener drive systems development for over 75 years. Our longtime commitment to innovation and problem solving has resulted in our products being recognized the world over for their superior design.

Forward-thinking drive systems for forward-thinking vehicles.

No automotive company would think of specifying decades old components for their vehicles, yet some continue to use nearly 50-year-old generic Phillips screws on their production lines. Often manufactured with minimal oversight, their precision and quality can be uncertain. With new, state-of-the-art, Phillips Drive Systems, there is a modern alternative to out-of-date, low-tech assembly methods.

Quality you can count on from Detroit to Munich.

Phillips takes the integrity of its drive systems very seriously. In addition to mobilizing a global network of first-rate licensed manufacturers, we pioneered worldwide quality-monitoring programs that assure the reliability of Phillips Drive Systems wherever your production lines are located.

Lighter, stronger vehicles, increased assembly speeds, and lower costs.

Phillips Drive Systems are engineered for high performance, design flexibility and lower overall production expense. Specifying genuine Phillips Drive Systems can add profits to your bottom

line by reducing vehicle weight and material usage, costly component damage caused by cross-threading, or from cam-out and improper assembly torque. Moreover, they provide easier, faster and more accurate assembly, as well as simpler disassembly for maintenance, repair, or warranty work.

From transmissions to advanced hybrid components, Phillips Drive Systems are ideal for assembly environments where fastening critical joints, cutting or forming threads, and stable one-handed assembly are required. Drawing on our vast engineering experience, we will work with you to develop custom fastener design solutions for your products and assembly processes with attention to strength, head height, weight, threading, length, and diameter.

Furthering the trend towards green technology.

The desire by automotive companies to provide their customers with more environmentally friendly products continues to grow. Leading the way in Phillips' efforts to meet that demand and offer a green drive system is our MORTORQ® SUPER. Designed with less material to reduce head height and weight, MORTORQ SUPER helps conserve precious resources.

Call toll free internationally at **(855) 580-0941** or visit www.PhillipsDriveSystems.com to see how we can help increase assembly speeds, reduce rework and lower costs.



Make sure you're getting genuine Phillips' design, engineering, quality, reliability and performance. Only the drive systems indicated meet the rigorous standards required to carry the respected Phillips name.

© Copyright 2012 Phillips Screw Company ACR®, HEXSTIX®, MORTORQ®, PHILLIPS II®, PHILLIPS SQUARE-DRIV®, and POZIDRIV® are trademarks of Phillips Screw Company. TORX® is a registered trademark of Acument Intellectual Properties, LLC.



CONTACT OUR CORPORATE OFFICES:

Phillips Screw Company, Inc.
1 van de Graaff Drive, Suite 404
Burlington, MA 01803 USA

WEB www.phillips-screw.com
TOLL FREE (855) 580-0941
EMAIL Automotive@phillips-screw.com